



Walara Series 425W G3P

Australia's first manufactured n-type solar pv module.

- Australian Made.**
The Walara Series is a true evolution in Australian renewable energy industry manufacturing. Designed and engineered by a local team based in South Australia who are available for service and warranty support.
- High Efficiency Cells.**
The first Australian made panel featuring N-Type technology intergrated into premium power class laser-cut bifacial cells for higher output, higher efficiency and increased durability.
- Intelligent Design.**
Specially designed stronger, rigid 35_{mm} frame with less flex, protecting the cells and increasing integrity and longevity through less micro-cracks.
- Zero Defect Manufacturing Process.**
Our Zero-Defect Manufacturing process guarantees that every Tindo panel undergoes rigorous testing at 7 predetermined quality checkpoints ensuring high performance for the lifetime of the product.
- Proven Performance in Australia's Harshest Conditions.**
Our panels are mounted and performing everyday at the Desert Knowledge Testing Centre in Alice Springs. Tindo panels are consistently one of the highest performing panels at the centre. – dkasolarcentre.com.au



Walara 425G3P Data Sheet

V12-240826

Mechanical Characteristics

Cells per panel	108 Half Cells
Cell Type	N-Type Cells (182 x 182mm)
Panel Dimension	1722 x 1133 x 35 mm
Panel Weight	22 Kg
Front Glass	3.2mm Fully tempered Double ARC Glass
Frame	Anodized Aluminum Alloy (T6) / Black
Junction Box	3 bypass diodes / IP68 rated
Cable	1200 mm(+/-), 4mm2 or Customised Length
Connector Type	Stabli-MC4 / KST4-EV0 2(M), KBT4-EVO 2(F)

Thermal Characteristics

RATING	UNIT	VALUE	
Operating Temperature	%	-40 ~ +85	
Maximum System Voltage (IEC)	VDC	1500	
Maximum Series Fuse Rating	A	30	
Nominal Module Operating Temperature	°C	45 ± 2	
Temperature Coefficient	Isc	%/°C	0.045
	Voc	%/°C	-0.25
	Pmax	%/°C	-0.32

Qualification test

Thermal cycling test	- 40°C to 85°C for 200 cycles
Damp heat test	85°C and 85% relative humidity for 1000 hr
Mechanical Load test	5400Pa (Front) / 2400Pa (Rear)
PID test	1500 VDC, 96h, 85% RH, 85°C
Hail Impact test	25mm hail at 23m/s from 1m distance

Cyclone tested by Structural Engineering Consultants Australia (SECA) Pty Ltd - certificate available on request

Safety factor of *static load test: 1.5 (Test load = Design load x Safety factor)
NexTracker installation : Front load 1800 Pa / Back Load 1800 Pa

Safety Ratings & Warranties

Safety Application Class	Class II
Fire Safety Classification	Class C
Certifications	IEC 61215 , IEC 61730
Warranty	25 years limited product warranty
Performance Guarantee	25 years limited warranty 87.4% power

Electrical characteristics

108HC Cell Module	Walara-425G3P		
ITEM	UNIT	STC*	NMOT**
Max. Power (Pmax)	Wp	425	323.9
Max. Power voltage (Vmp)	V	32.2	30.36
Max. Power current (Imp)	A	13.2	10.67
Open circuit voltage (Voc)	V	38.91	36.98
Short circuit current (Isc)	A	14	11.29
Module efficiency	%	21.8	
Positive power tolerance	W	0 ~ + 5	

*STC (Standard Test Condition): 1,000 W/m² , AM 1.5, 25°C

**NMOT(Nominal Module Operating Temperature) : Irradiance at 800W/m, Ambient Temperature 20°C, Wind Speed 1m/s, air mass of AM1.5

Tolerance of Measuring Pmax, Voc & Isc ± 3% within each watt class at STC

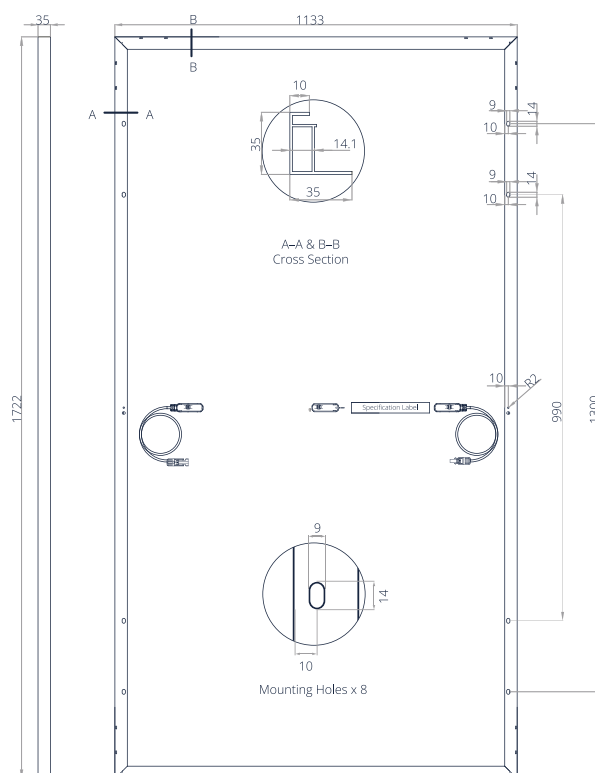

Packaging

Stacking Method	Horizontal	Vertical (Optional)
Panels per Pallet	30	31
Loading Capacity (40HQ)	600	806

Note:

- The specifications included in this datasheet are subject to change without notice.
- The electrical data given here is for reference purpose only.